

# Sanicubic® 1VX VORTEX LIFT STATION - PART N° 049

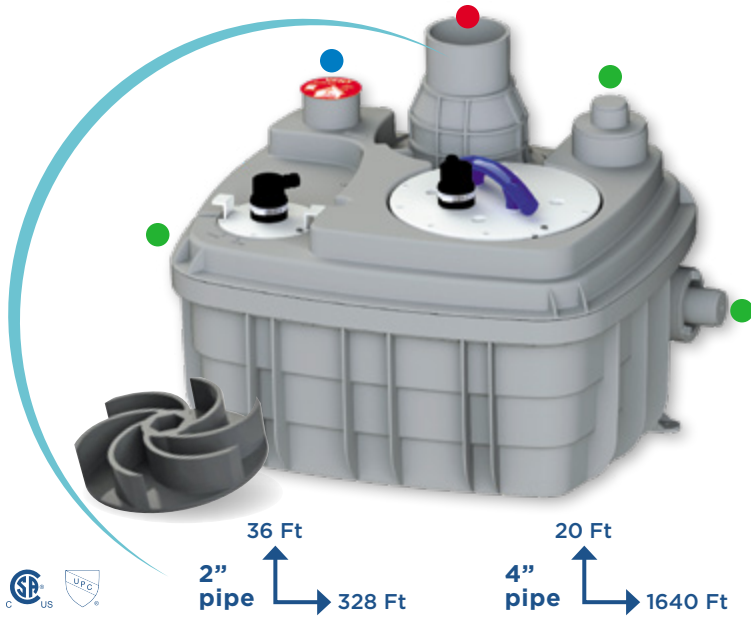

36 Ft  
2" pipe → 328 Ft

20 Ft  
4" pipe → 1640 Ft

## CONNECTIONS

- Discharge: 2" or 4"
- Inlet: Three 1-1/2" or 4"
- Vent: 1-1/2"

### Wastewater (Residential, Commercial Applications)

The Sanicubic 1 VX is heavy duty simplex vortex system used to pump away wastewater from several bathrooms and fixtures from an entire building structure. This system is able to discharge the waste up to 36 feet vertical and/or 328 feet horizontal using 2" pipe or up to 20 feet vertical and/or 1640 feet horizontal using a 4" pipe.

This lift station is ideal for uncontrolled environments in both residential and commercial applications (ie. rental unit, offices, warehouses, etc). The Sanicubic 1 VX incorporates a vortex impeller capable of handling up to 2" solids.

## PRODUCT FEATURES

### PERFORMANCE

- Maximum pumping height: 36 Ft (2"), 20 Ft (4") - (43 Ft Shut-off).
- Maximum flow rate: 125 GPM (2"), 137 GPM (4").

### ADVANTAGES

- Installed directly on the ground.
- Easy access for maintenance.
- System activates with a fail-proof air pressure switch system with triple redundancy.
- Vortex impeller (up to 2" solids).
- Direct and safe access to pump.
- External control box included.
- Wired alarm included.
- Rated IP68 with external control box and alarm standard.



## PUMP CURVE

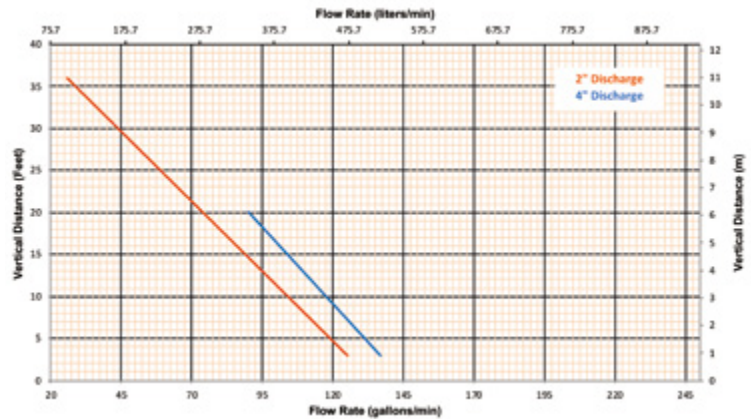

## STANDARD ACCESSORIES

### Control box



### Wired alarm unit



## OPTIONAL

**Descaler** (Part N° 052) See page 28





## TECHNICAL SPECIFICATIONS

**Pump type:**

Vortex

**Electrical:**

220-240 V (208V min) - 60 Hz / 12 Amps (Max)

**Motor:**

1.5 HP oil-filled thermally protected motor

**Capacitor rating:**

30 microfarad

**Operating Temperature:**

158°F

**Power cord length:**

98 inches

**Noise level:**

≤ 70 dBA (Lp) (measured at 3 ft.)

**Discharge pipe diameter:**

2" or 4"

**Discharge rate at 36 ft (2"):**

26 GPM

**Discharge rate at 3 ft (2"):**

125 GPM

**Discharge rate at 20 ft (4"):**

90 GPM

**Discharge rate at 3 ft (4"):**

137 GPM

**Shut-off head:**

43 ft.

**Normal running time:**

Depends on number of fixtures

**Capacity:**

15.9 gallons / 60.2 liters

**Inlets:**

1-1/2" or 4"(side), 1-1/2" or 4"(top)

**Method of activation:**

Pressure switch, Circuit board

**Shower/bathtub base height:**

11" min

**Weight:**

68 lbs / 30.8 kg

**Certifying agencies:**

CSA (IPC, NSPC), IAPMO (UPC)

**Recommended accessories:**

Descaler

**Connections:**

Toilet, sink, shower/bathtub, washing machines (direct connection), etc.

## DIMENSIONAL DRAWINGS

